

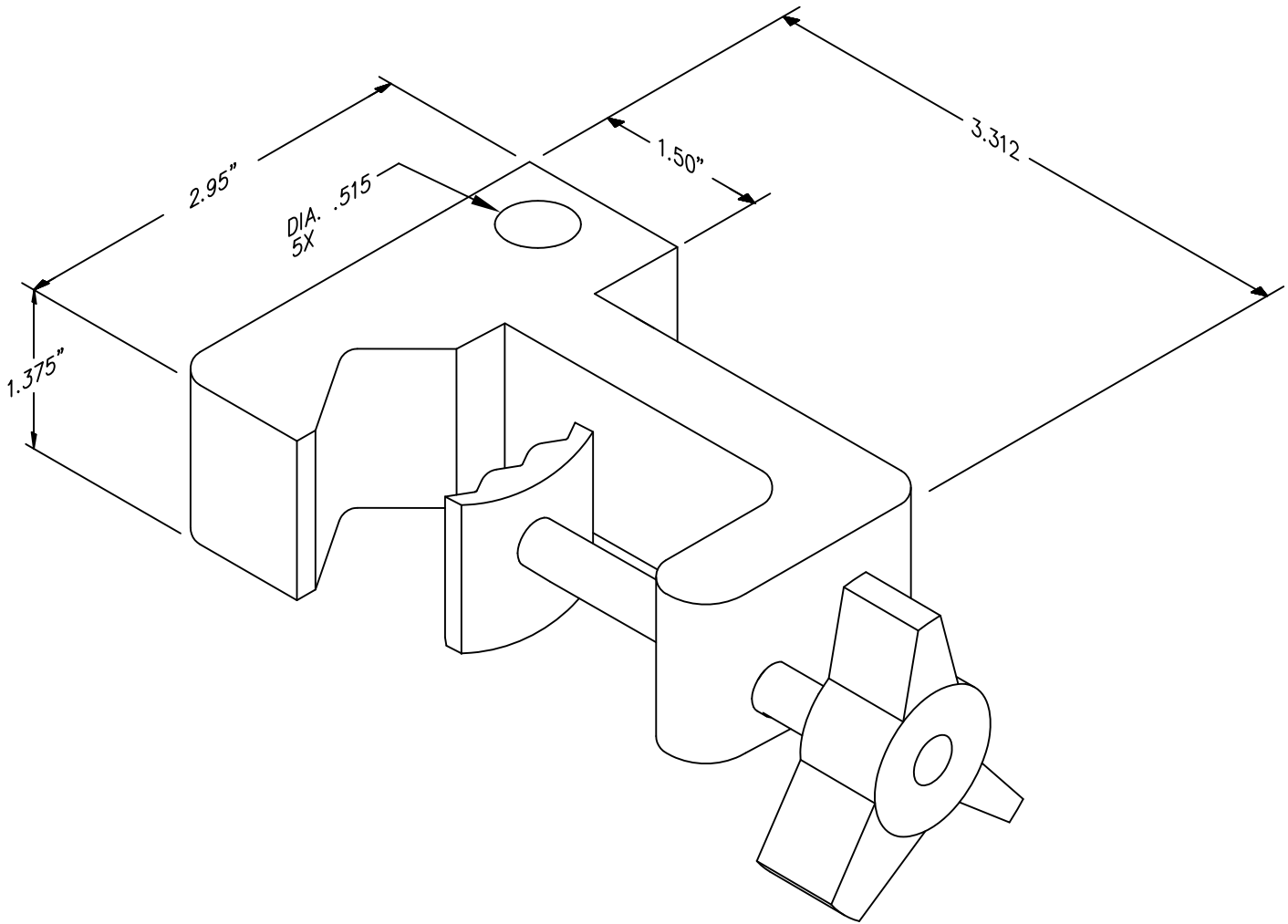

# CAT. NO. BC100A



BLACK ANODIZED ALUMINUM CLAMP WITH DETACHABLE KNOB, SELF ADJUSTING THRUST PLATE, CLAMP ADJUSTS FROM 1/2" TO 1-1/2".  
SHIPPING BOX IS. 12 X 12 X 18. (BULK PACKAGING) SHIPPING WEIGHT IS 45 LBS.

**NOTE:** ALL DIMENSIONS ARE IN INCHES.

ILL-BC100A REV A 